

Please read this operation manual Carefully before using the commercial induction cooker in the right way

Special Declaration

All the content of this manual has been already checked carefully, Any misunderstanding or printing error will be kept by the manufacturer

Any technical improvement will be recorded in the new manual which is printed newly, Any change of color and design will no notice by the manufacturer, Please check the real products.



Four Burners Commercial Induction Cooker

Model: LT-TB300IV-B135 / B105

- Thanks for choosing Lestov Induction Cooker
- Please read this manual before using
- Please keep this manual after reading for checking in the future
- The company reserves the right to modify

1. Operating Principle

The Induction cooker is a kind of new kitchen product in the kitchenware market, which had broken the traditional way of cooking by using the most advanced magnetic field induction eddy current heating technology. As the current crosses, the coil and the magnetic field will be formed. When this magnetic line cross through the magnetic field and whirlpool have been formed and make the effect of a pot or boiler, heating the food in the pot.

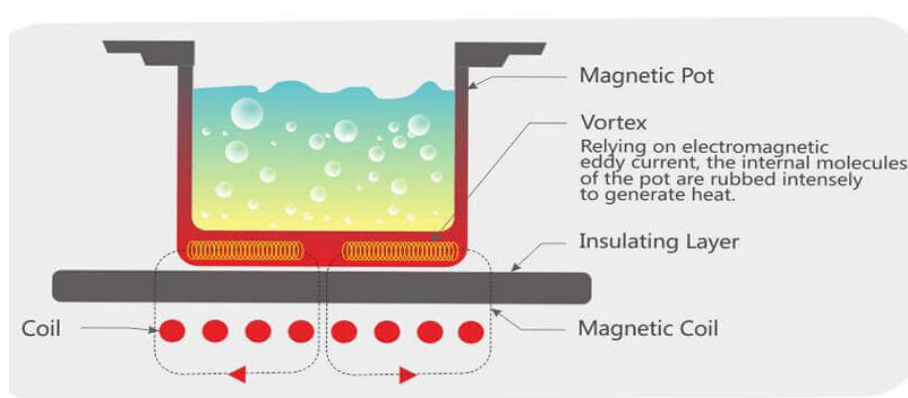

2. Technical Specification

(1) Magnetic field induction eddy current heating technology

Current (17-40) kHz cross the coil and make a magnetic field, when the magnetic line crosses the field, heat will be caused to heat the pot and cook the food in the pot

(2) AC: 220V (Inlet Voltage 380V)-Current: 50 / 60 HZ-Power: 4*3.5KW / 5KW

(3) The requirement for the pot which used in the induction cooker

Because the no magnetic materials have not made the magnetic line, So the whirlpool can not be formed, and so, the heat can not be made. Moreover, the magnetic materials with bad electric conduction can not make bigger whirlpools that need to make little heat($P=I^2R$). So only high conductive materials can use as the induction pot, such as iron pots, A3 iron pots, and stainless steel pots.



Noted: When without any operation for more than 3 hours, the cooker will shut off automatically

3. Installation and Debugging

- ❖ Behind the stove, there should install an inlet water pipe hydro-valve to maintain it easily. The power line is at the bottom of the stove with 220V 1~ or 380V 3~. It must be installed at the GFCI or reliable power ground. Must let the professional person install the water and power supply.
- ❖ There should reserve a maintenance channel more than 35 centimeters behind the stove, if not, there should reserve a 5 centimeters place for heat dissipation and a removable forward to maintain it easily.

380V-3N Power Cable Configuration Diagram

1. Please connect power supply according to the wiring diagram in the machine. Please carefully confirm the data on the product tag and correctly distinguish the fire wire L1, fire wire L2, fire wire L3 and earth wire.

2. The equipment configuration of the power cable must be carried out by professionals. The power cable used should be able to with stand the current of the equipment and firmly installed, the fixing screw must be tightened, and the ground wire must be reliably grounded.

3. When connecting power supply input cables, press the cable with U type presser sheet to prevent accidents caused by looseness.

4. The power supply of the equipment shall be connected to the power grid only after externally connected to the leakage protection switch with sufficient current capacity, it must be easily disconnected, and the ground wire must be reliably grounded without any switch control.

	5kW	8kW	12kW	15-20kW	25-35kW	40kW-45kW	50kW
Rated current	7.6A	12.2A	18.2A	22.8A-30.4A	38A	45.6A-60.8A	68.4A-76A
cable configuration	3 phase 4 wires 4*4mm ²	3 phase 4 wires 4*6mm ²	3 phase 4 wires 4*10mm ²	3 phase 4 wires 4*16mm ²	3 phase 4 wires 4*25mm ²	3 phase 4 wires 4*35mm ²	3 phase 4 wires 4*50mm ²
Leagage switch configuration	30A	30A	36A	60A	80A	80A	100A

220V Power Cable Configuration Diagram

- Please connect power supply according to the wiring diagram in the machine. Please carefully confirm the data on the product tag and correctly distinguish the fire wire L, zero N and earth wire.
- The equipment configuration of the power cable must be carried out by professionals. The power cable used should be able to stand the current of the equipment and firmly installed, the fixing screw must be tightened, and the ground wire must be reliably grounded.
- When connecting power supply input cables, press the cable with U type presser sheet to prevent accidents caused by looseness.
- The power supply of the equipment shall be connected to the power grid only after externally connected to the leakage protection switch with sufficient current capacity, it must be easily disconnected, and the ground wire must be reliably grounded without any switch control.

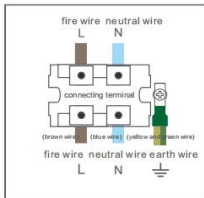
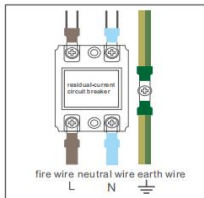
Power cable box configuration-input ports Power cable configuration-to main power supply

Rated power	1kW	2kW	3.5kW	5kW	7kW	8.5kW	10kW
Rated current	4.5A	9.9A	15.9A	22.7A	31.8A	38.6A	45.5A
Cable configuration	single phase 3 wires 3x1.5mm ²	single phase 3 wires 3x2.5mm ²	single phase 3 wires 3x4mm ²	single phase 3 wires 3x6mm ²	single phase 3 wires 3x10mm ²	single phase 3 wires 3x16mm ²	single phase 3 wires 3x25mm ²
Leakage switch configuration	32A	32A	32A	60A	60A	80A	80A

4、 Introduction of Operation

- ❖ Make the power switch to the “0” position.
- ❖ After switching on, “Bee” all the LED displays will flash one time. Then one-second later power light (red) flickers, and then the working lights(blue) shut down.
- ❖ Twist the magnetic switch, and the power light, and the working light flash, the cooling fan works, the display shows 1, and the stove starts work at gear 1; then adjust the switch to different power and the LED shows the working gears. When twisting the gears the stove sounds “Bee” and there are 8 gears.
- ❖ After the cook is finished, twist the switch to the on-off button, power light and working light will be shut off, Motor fan will continue working for 1 Min and power off automatically.
- ❖ After the fan stops working, shut off the power.
- ❖ After using, the way of controlling the close unit can not depend on the temperature detector in the stove.
- ❖ This equipment is suitable for ambient temperature: - 10 ~ 38 °C, humidity ≤90%.

5、 The Parameter of Power Gears

Power Gear	1	2	3	4	5	6	7	8
Current (A)	7.2	7.2	9.6	12.3	14.8	17.3	19.9	22.5
Power (W)	1584	1584	2112	2706	3256	3806	4378	4950
Description	Gap heating, stop for 3 seconds every 3 seconds		Continuous Heating					

Power Gear	1	2	3	4	5	6	7	8
Current (A)	4.6	4.6	6.1	8.2	9.8	11.7	13.4	15.1
Power (W)	1012	1012	1342	1804	2156	2574	2948	3322
Description	Gap heating, stop for 3 seconds every 3 seconds		Continuous Heating					

6、 Cleaning and Maintenance

- ❖ When cleaning the induction cooker, it must be powered off, strictly prohibit flushing water or cleaned with the steam cleaner, and should be cleaned with a cleaning cloth.
- ❖ To ensure the good heat dissipation efficiency of the core machine, we suggest its inlet should be cleaned monthly.

7、The Structural Representation

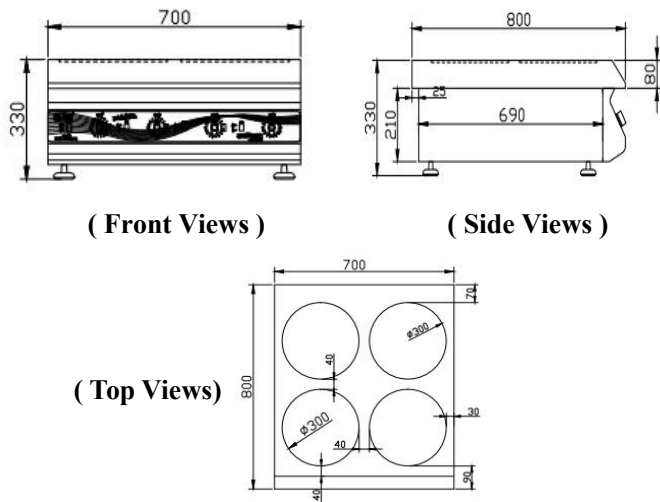

8、Safe Operation Notes

- ❖ Please note when using the Lestov commercial Induction Cooker:
- ❖ Please read this manual carefully before using it.
- ❖ No water into the cooker and ventilation and dry condition are needed.
- ❖ When using the cooker, please don't switch the knob frequently, which may lead to no operation effect.
- ❖ Do not shut off the power when the cooker is working for protecting the power switch damaged.
- ❖ Before cutting off the power, Please confirm the cooker and motor fan stopped.
- ❖ When using, please don't shelter the LED display in order to indicate the work condition of the cooker.
- ❖ Do not use any pot and kitchenware which not certificated by the manufacturer.
- ❖ Do not block the inlet and outlet.No flush the motor fan and outlet.
- ❖ After shutting off the power then you can clean the cooker, no flushing water on it and no steam cleaner or similar cleaner could be used to clean the cooker.
- ❖ Aluminum containers and plastic containers can not be used in glass ceramics, and

the glass ceramics is not the container, no storage thing is permitted. Do not place any kitchenware pot or other spoon knife on the glass ceramics for protection broken.

- ❖ Attention when using the cooker, any ring and watch with the operator will be heated.
- ❖ When connecting power, the leakage protection switch is needed.
- ❖ If the cooker is close to the wall, fire protection should be taken, and follow the fire protection policy strictly.
- ❖ Any maintenance which is not authorized by the manufacturer will not be allowed, please contact the nearest agent.
- ❖ Warning: The line cord needs to be repaired by the manufacturer or authorized agent.
- ❖ Warning: No dismount of the machine for laypeople because of the high voltage in the machine and dangers.
- ❖ The operator with a pacemaker could not use this product.
- ❖ Warning: Children and the disabled do not use this machine.

9、Mark Meaning

- ⚠ GB/T 5465.2-5140 **None ionization electromagnetic radiation** Indicating the radiation is higher than normal standard or there is potential risk; or indicating the device or the system for example the radiate equipment in diagnosis or treatment or the areas of applying medical electronics device which used radio frequency electromagnetic energy firing.
- ⚡ GB/T5465.2-5036 **Dangerous voltage** Means dangerous voltage caused danger.
- ⚠ GB/T 5465.2-5021 **Equip potential** Identifying the terminals which make each part of the system in the same potential after being connected, which is not always the ground potential such as partial connection.
- ⚠ **Earthed circuit** Identifying the terminal of the outside protection conductor which prevents electric shock or the terminal connected with the protective earthing electrode.

10、 Error Maintenance

When the cooker do not work, please check below items:

Error	Maintenance
(1) Power on, No “Bee” Sound	
① Check the main power cable	OK
② Check power switch power or leakage	Check leakage and circuit
(2) No working after switch on and cannot heating	
① Power switch is not in shut off gears when powered on	Switch the knob to shut off, restart
② Switch on LED no changing	Knob switch is broken, change a new knob
(3) When cooker working, no response or power reduce down and return to normal and repeat this error	① No operating cooker for more than 2 hours, restart the cooker
	② Overheat protection, check the power connection and fan working or not
(4) When heating, LED display shows “3” or “8”	Switch reset, then restart

11、 Error Code

E1	No pot	E5	IGBT Thermistor cut off	E9	Short circuit
E2	Overheat for bottom pot	E6	Low voltage	EA	Wire coil cut off
E3	Thermistor cut off	E7	High Voltage	EB	Fan no working
E4	IGBT overheat	E8	IGBT Over-current		

When you have checked up above without the trouble clearing please contact the distributor or our salesman